



Tartarini Auto S.p.A.
Via Bonazzi, 43
I-40013 Castel Maggiore (Bo)
tel.+39.0516322411
Fax Italy +39.0516322400 · Fax Foreign countries: +39.0516322401
Cap.Soc Euro 2.016.300 i.v. – Cod.Fiscale/Partita Iva 00885211201
E-mail: info@tartarinauto.it · www.tartarinauto.it

Castel Maggiore, March 11th 2008
To all our customers

RAIL SGI TAU EVO 08

It is available our new Rail SGI TAU EVO 08 (Picture 1) and it will replace starting from today our Rail Tartarini Standard that has been discontinued.

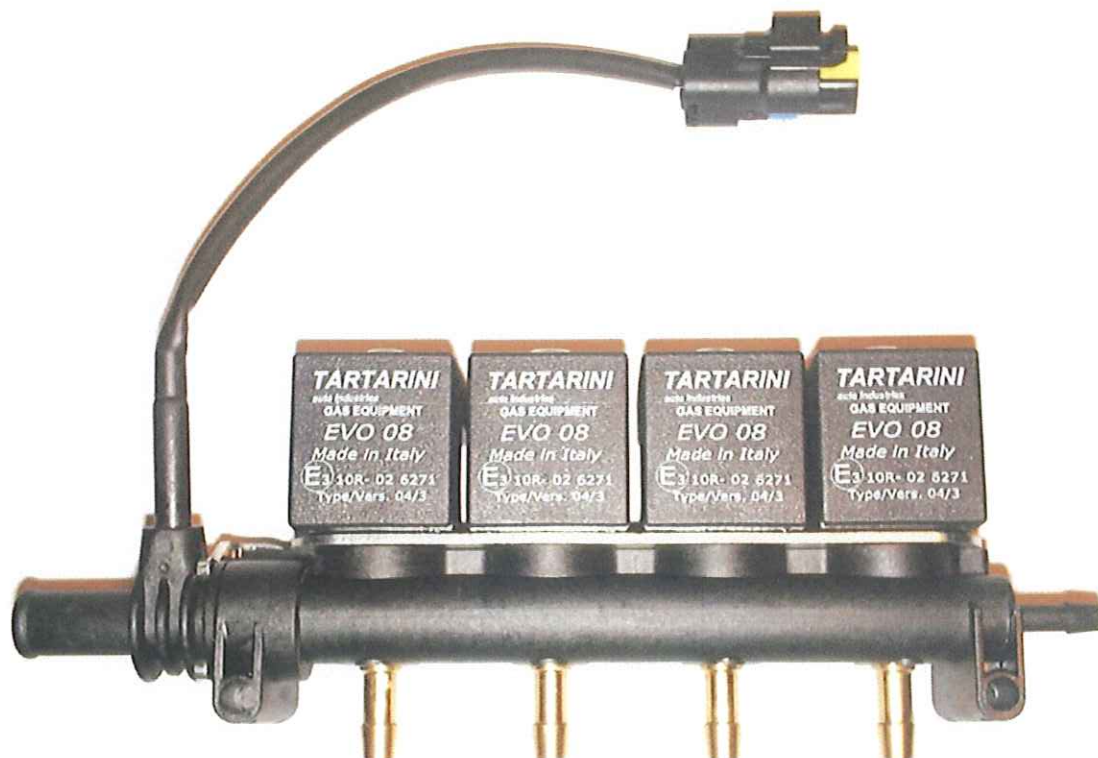

(Picture 1)

Following characteristics make it **perfectly interchangeable** with our **Tartarini Standard Rail**:

1. Electronic compatibility: Every version of Tartarini electronic unit.
2. Electric compatibility: AMP 2 wires coil plugs.
3. Electric compatibility: integrated temperature sensor plug.
4. Pneumatic compatibility: 10-11 mm. internal diameter Gas inlet hose
5. Pneumatic compatibility: 6mm. Internal diameter rail-to-manifold gas hose
6. Pneumatic compatibility: 4mm. Internal diameter MAP signal hose

Main characteristics:



Tartarini Auto S.p.A.
 Via Bonazzi, 43
 I-40013 Castel Maggiore (Bo)
 tel.+39.0516322411
 Fax Italy +39.0516322400 · Fax Foreign countries: +39.0516322401
 Cap.Soc Euro 2.016.300 i.v. – Cod.Fiscale/Partita Iva 00885211201
 E-mail: info@tartariniauto.it · www.tartariniauto.it

Driving type	Pick&hold
Working pressure	0-3 bar
Working temperature	(-40;+120 °C)
Homologations	67R01 & 110R00
Opening time [1bar-12V]	3,5 ms
Closing time [1bar-12V]	2,2 ms
Temperature sensor type	NTC

This rail will use its own nozzles. The price of each bag containing 20pcs nozzles will remain unchanged.

In order to choose the **calibrated diameter of nozzles** according to the requested engine power, please refer to this chart:

Item code (bag of 20pcs)	Diameter (mm)	Number of nicks (Picture 2)	Power (KW) 3 cylinders	Power (KW) 4 cylinders
8960509	1.7	0	35	45
8960510	1.9	1	42	55
8960511	2.2	2	52	70
	Without nozzle	---	70	90

In order to obtain 3,0mm. diameter, do not introduce any nozzle. Internal diameter of the brass fitting is already 3mm.

The correct choice of nozzle can be verified with warm engine; gas injection time **in idle without loads** shall be between **3,5 and 4,0 ms.**

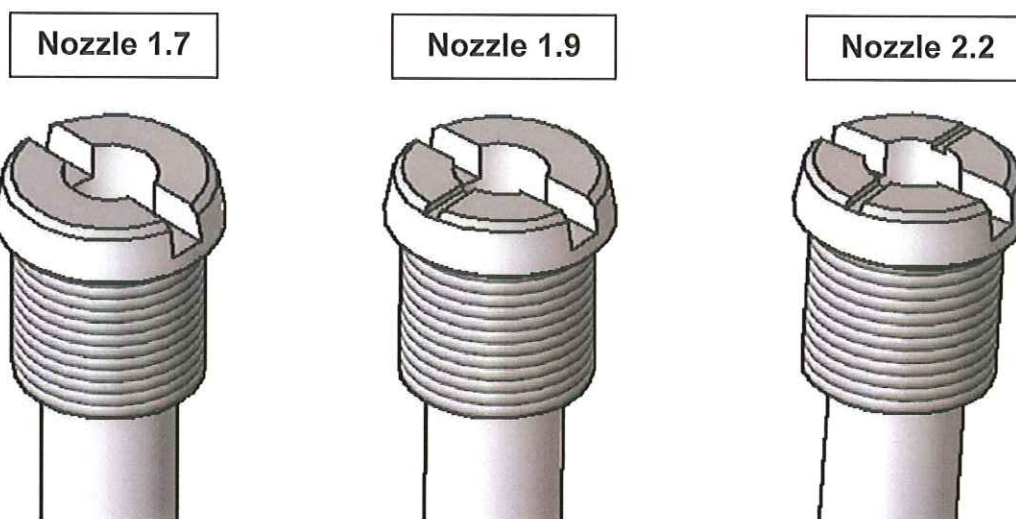

(Picture 2)



Tartarini Auto S.p.A.
Via Bonazzi, 43
I-40013 Castel Maggiore (Bo)
tel.+39.0516322411
Fax Italy +39.0516322400 · Fax Foreign countries: +39.0516322401
Cap.Soc Euro 2.016.300 i.v. – Cod.Fiscale/Partita Iva 00885211201
E-mail: info@tartariniauto.it · www.tartariniauto.it

These nozzles cannot be mistakenly used on Rail EVO 07, because the threading is different and the installer would note immediately.

For a correct configuration of this injector on our **SGI systems**, it is mandatory to select **TARTARINI EVO 08** as shown in Picture 3.

This choice is available and perfectly working, on our latest software programs on Tartarini Auto website www.tartariniauto.it (SGI version 5.4.0.C & NoDiagnosis 5.0.0.C).

The previous software versions will not have this option.



(Picture 3)

We remain at your complete disposal for any further information or clarifications.

Best regards

TARTARINI AUTO SPA