

DIAGRAM FOR 3 – 4 CYLINDER VEHICLES

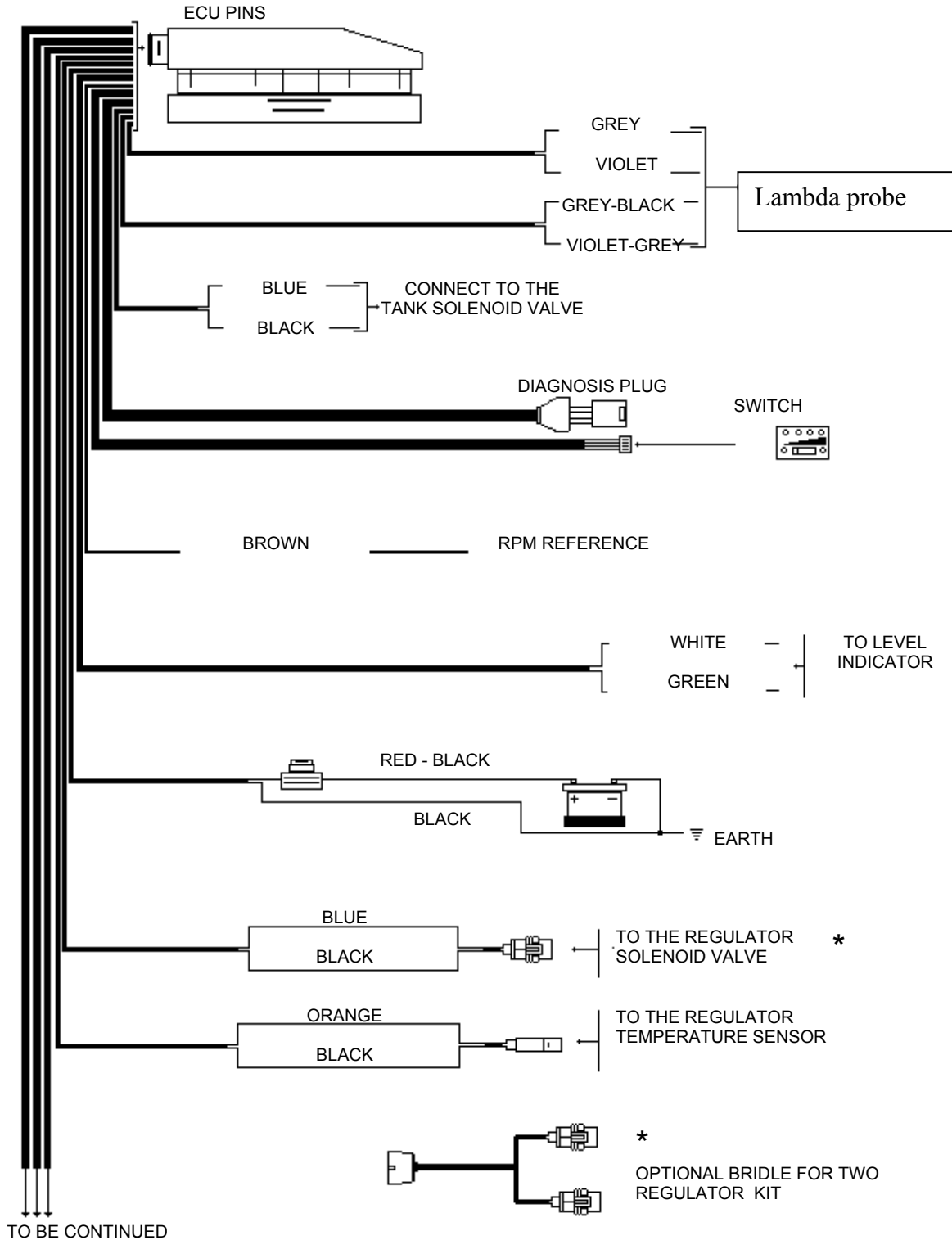

DIAGRAM FOR LPG 3 CYLINDER VEHICLES UP TO 85 KW

CONTINUING FROM PREVIOUS PAGE

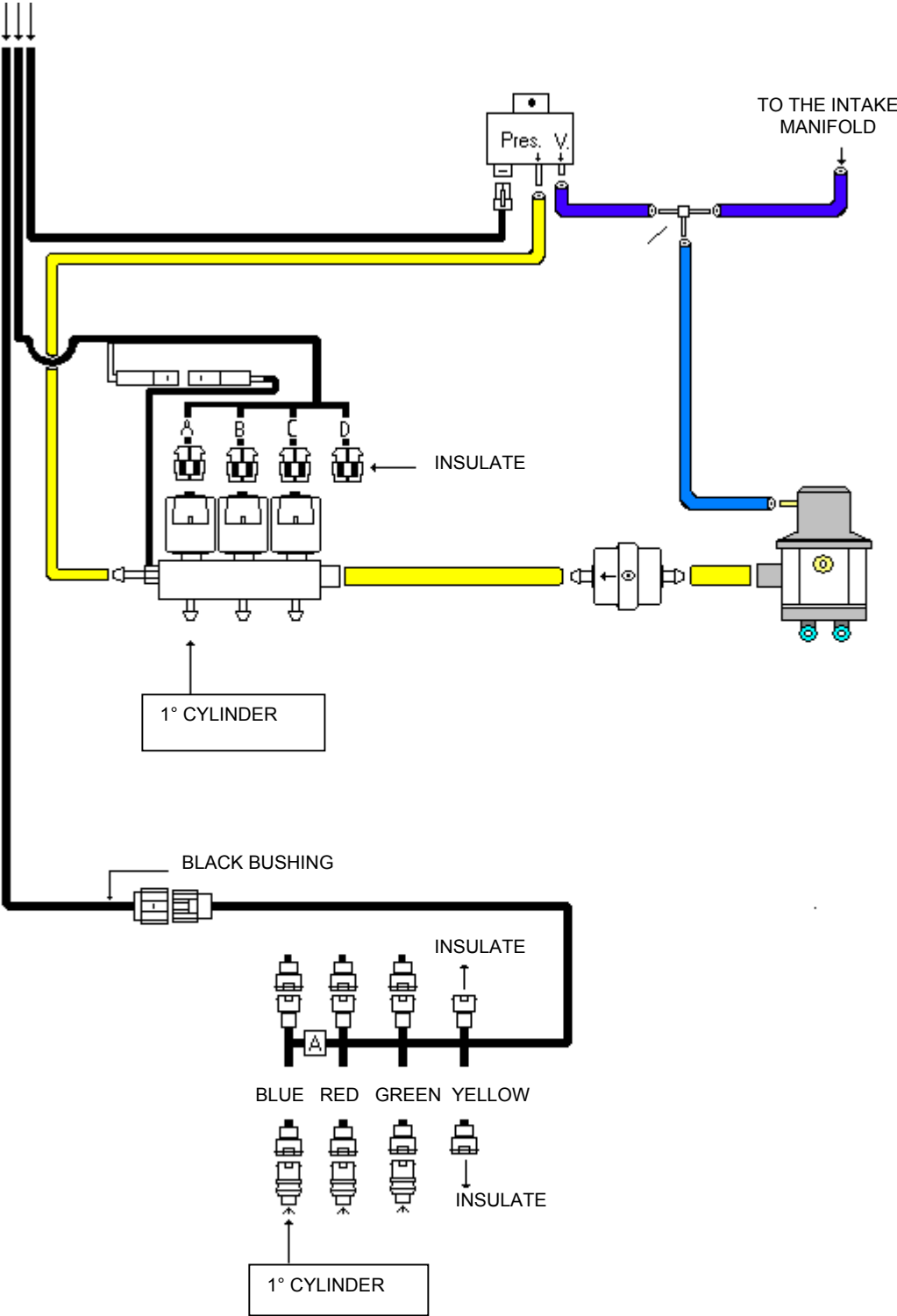

DIAGRAM FOR CNG 3 CYLINDER VEHICLES UP TO 85 KW

CONTINUING FROM THE PREVIOUS PAGE

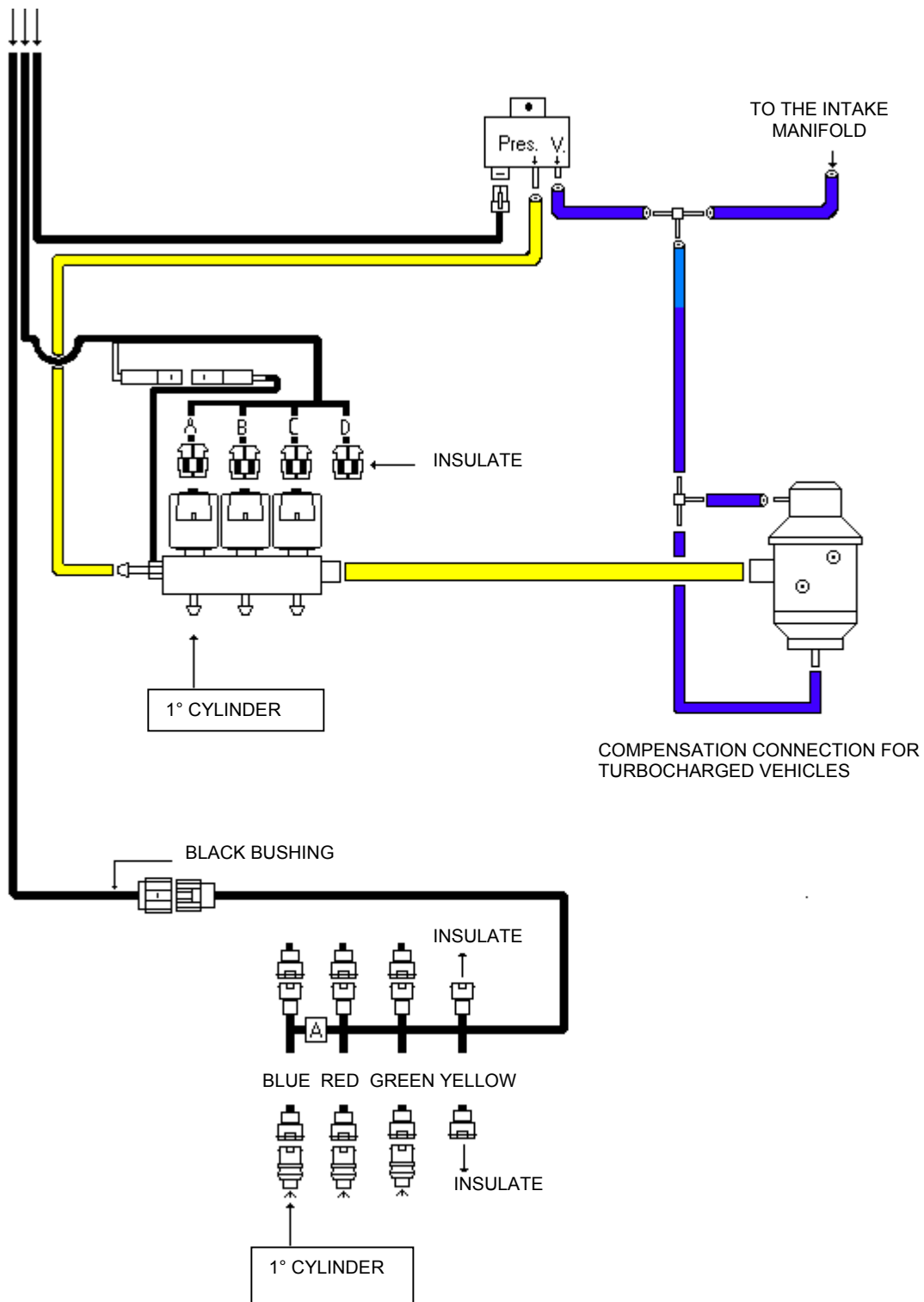
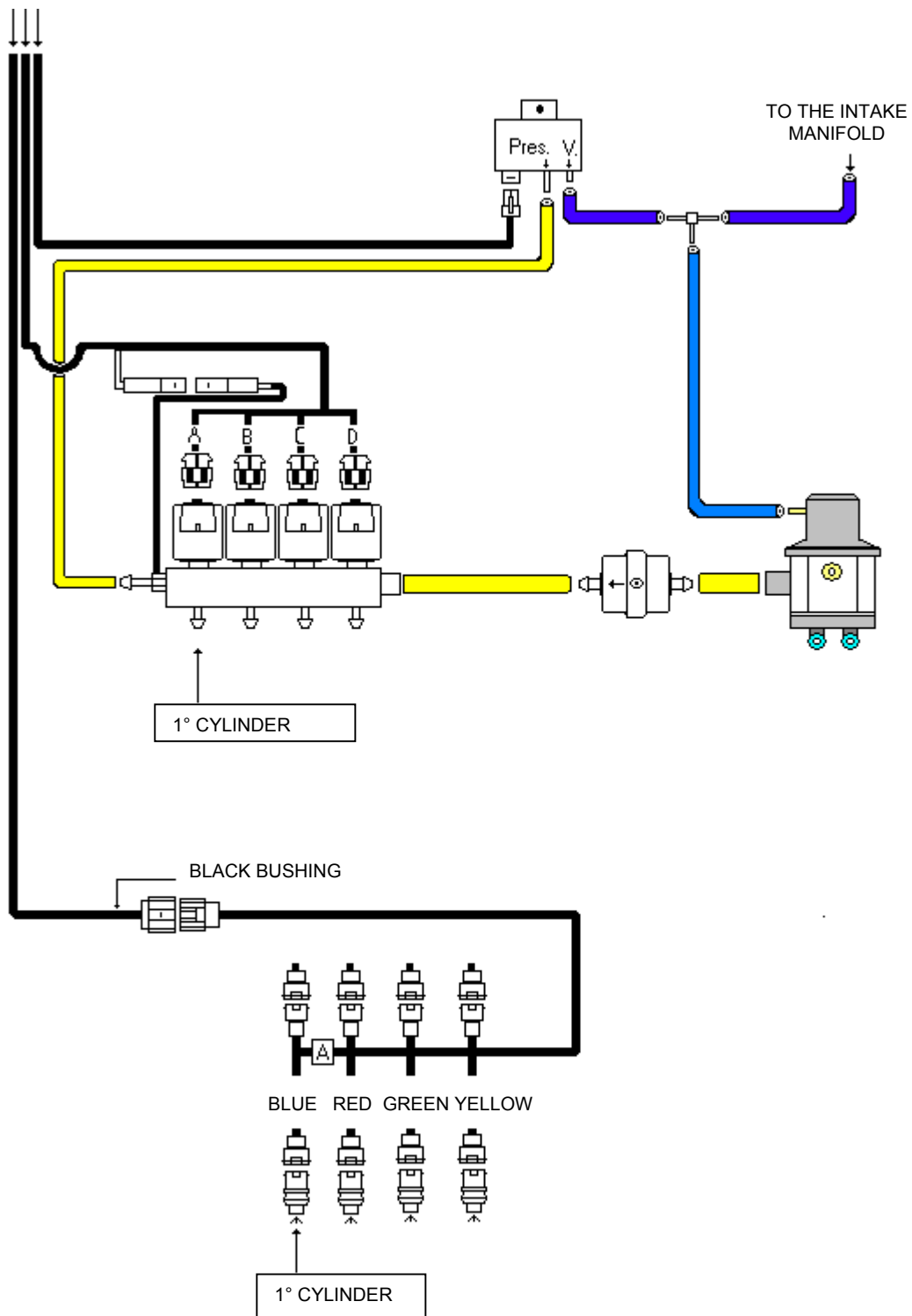

DIAGRAM FOR LPG 4 CYLINDER VEHICLES UP TO 110 KW

CONTINUING FROM THE PREVIOUS PAGE



DIEGRAM FOR CNG 4 CYLINDER VEHICLES UP TO 110 KW

CONTINUING FROM THE PREVIOUS PAGE

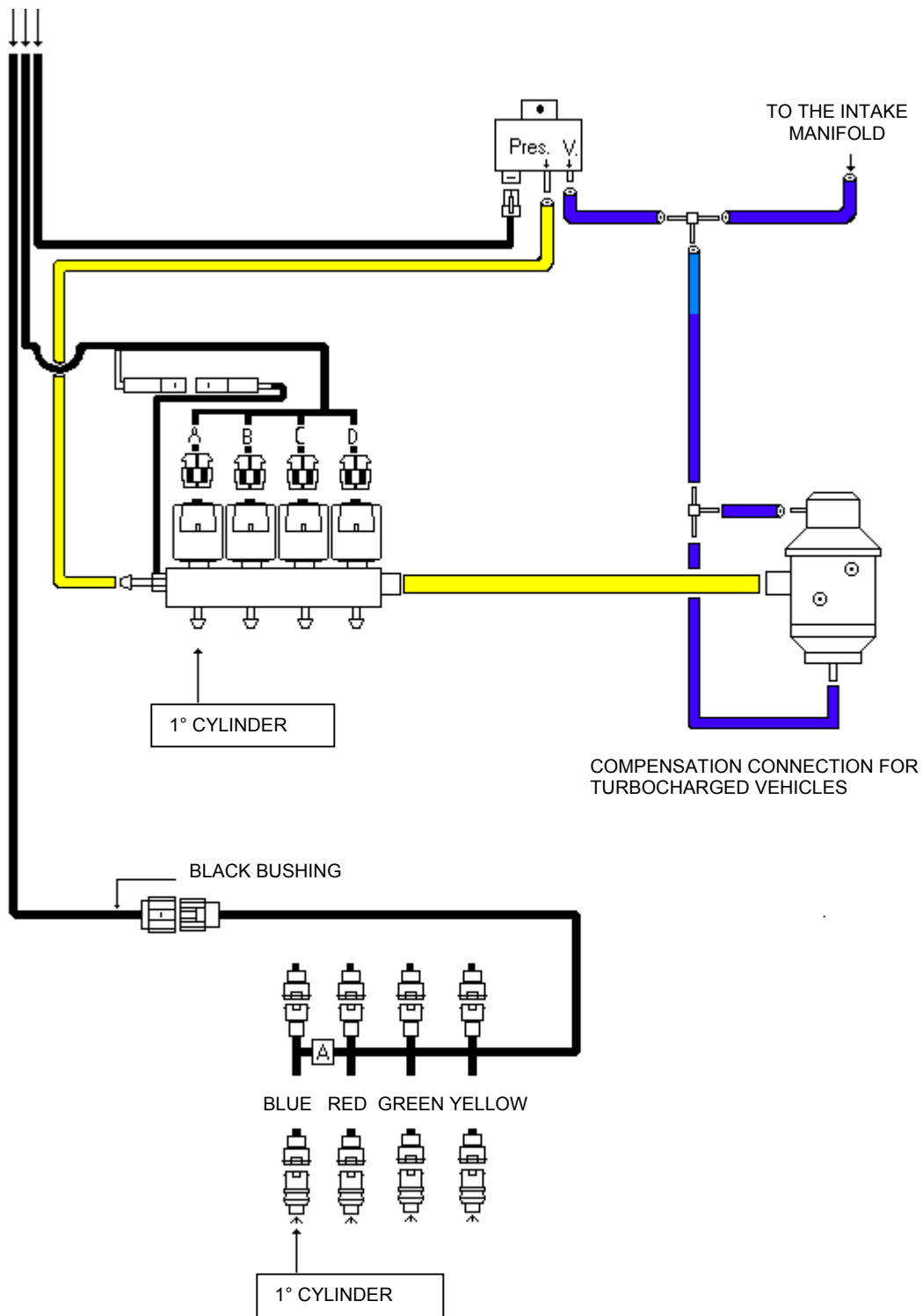

DIAGRAM FOR LPG 4 CYLINDER VEHICLES 2 REGULATORS UP TO 140 KW

CONTINUING FROM THE PREVIOUS PAGE

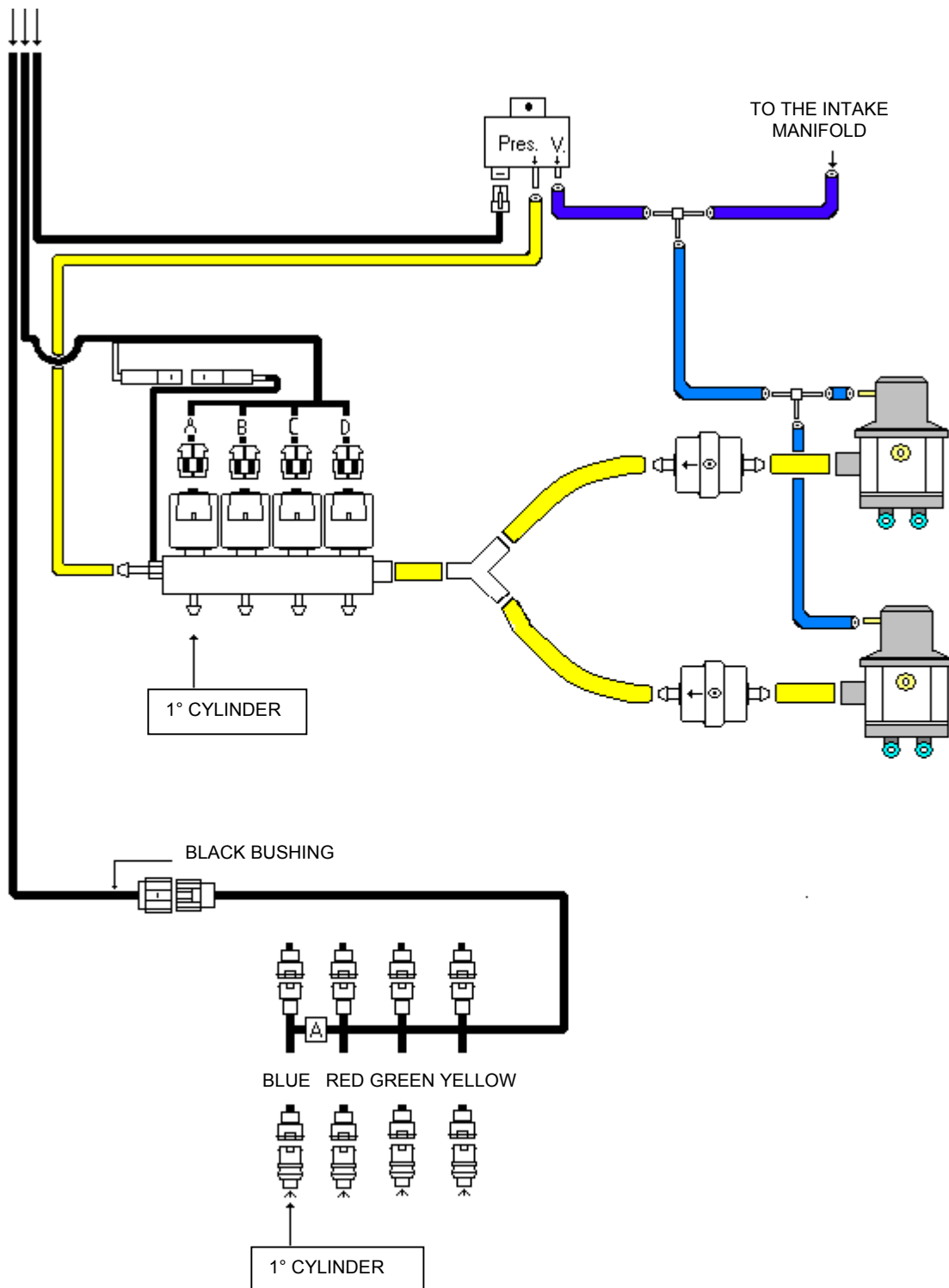

DIAGRAM FOR CNG 4 CYLINDER VEHICLES 2 REGULATORS UP TO 140 KW

CONTINUING FROM THE PREVIOUS PAGE

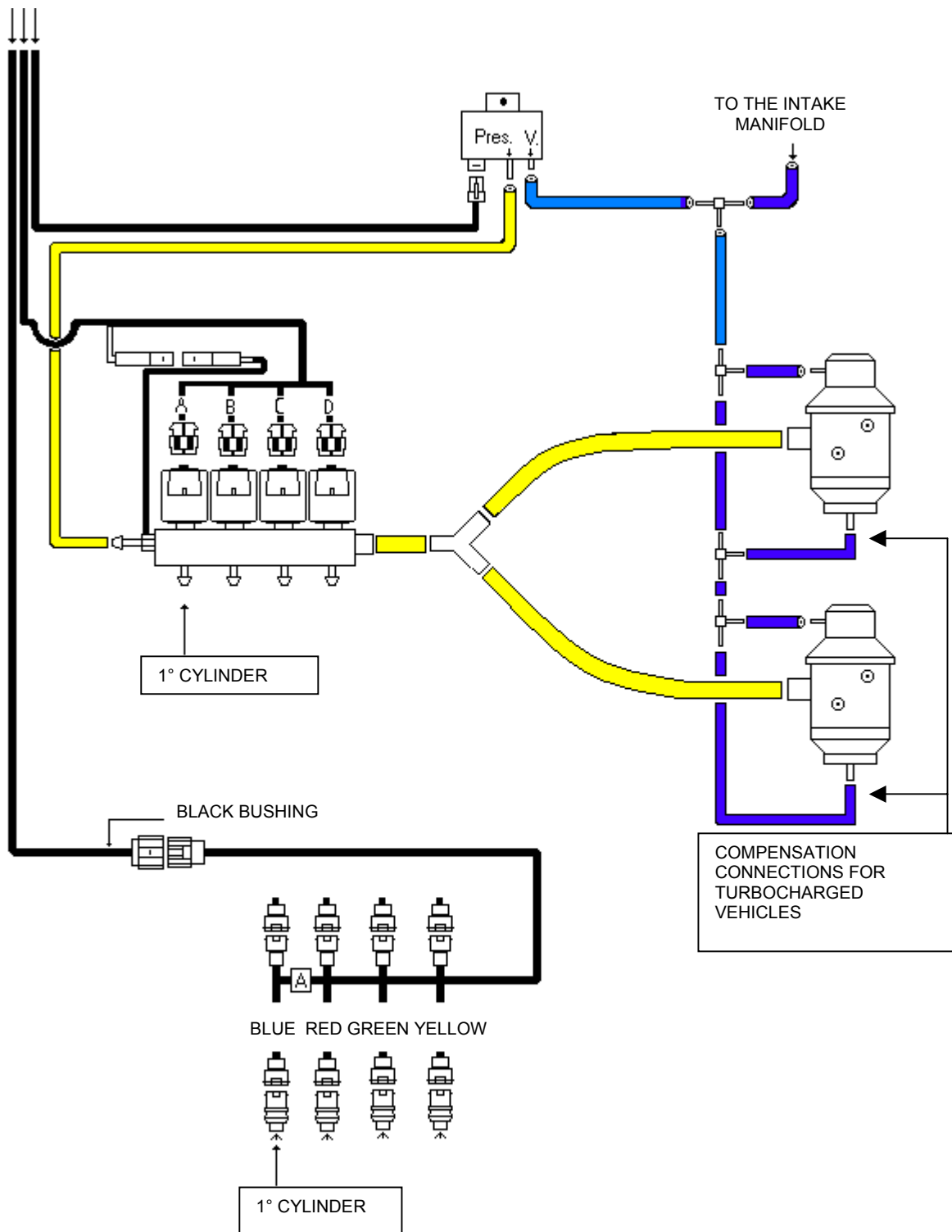

DIAGRAM FOR LPG 4 CYLINDER BOXER VEHICLES UP TO 110 KW

CONTINUING
FROM THE
PREVIOUS PAGE

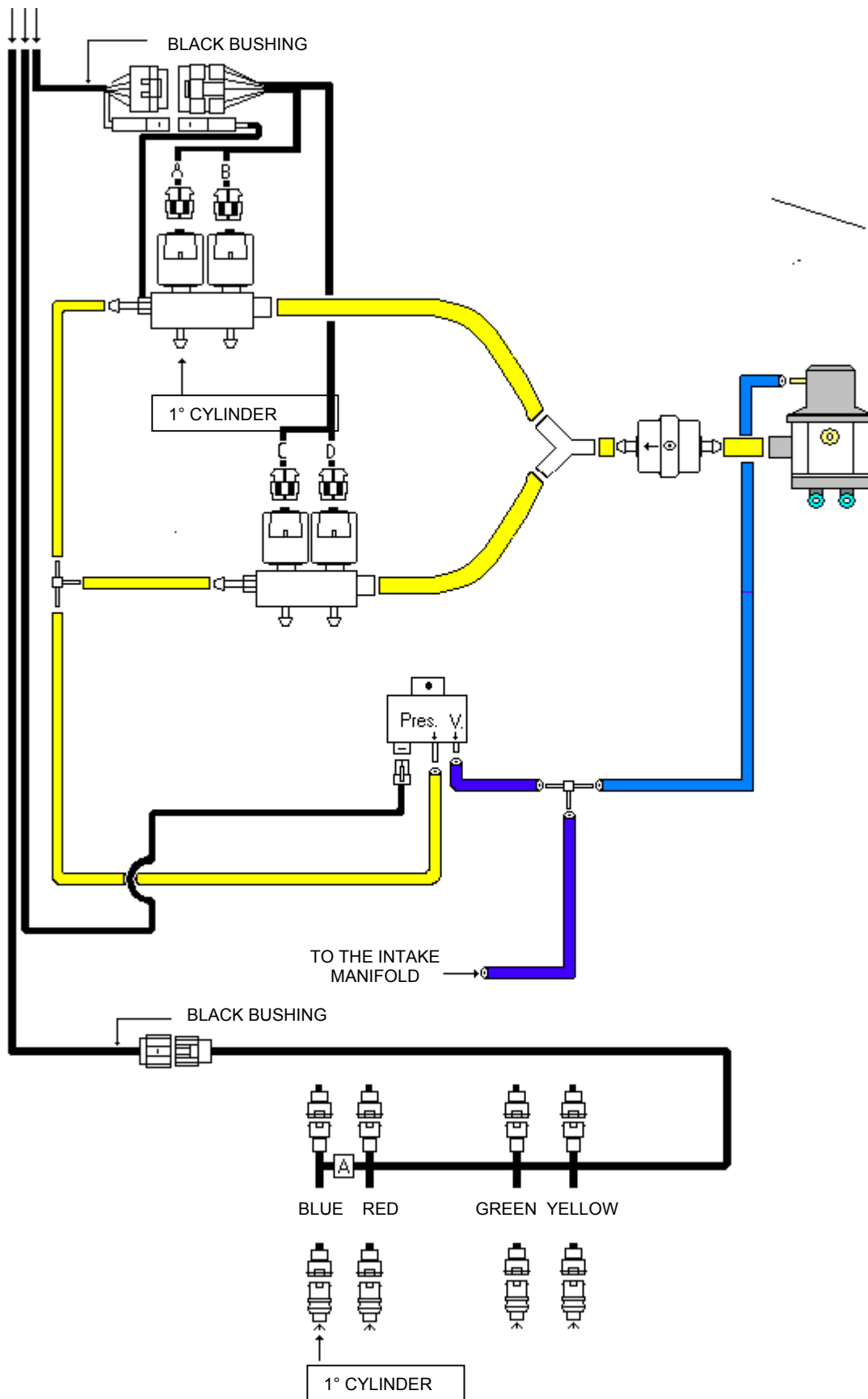

DIAGRAM FOR CNG 4 CYLINDER BOXER VEHICLES UP TO 110 KW

CONTINUING
FROM THE
PREVIOUS PAGE

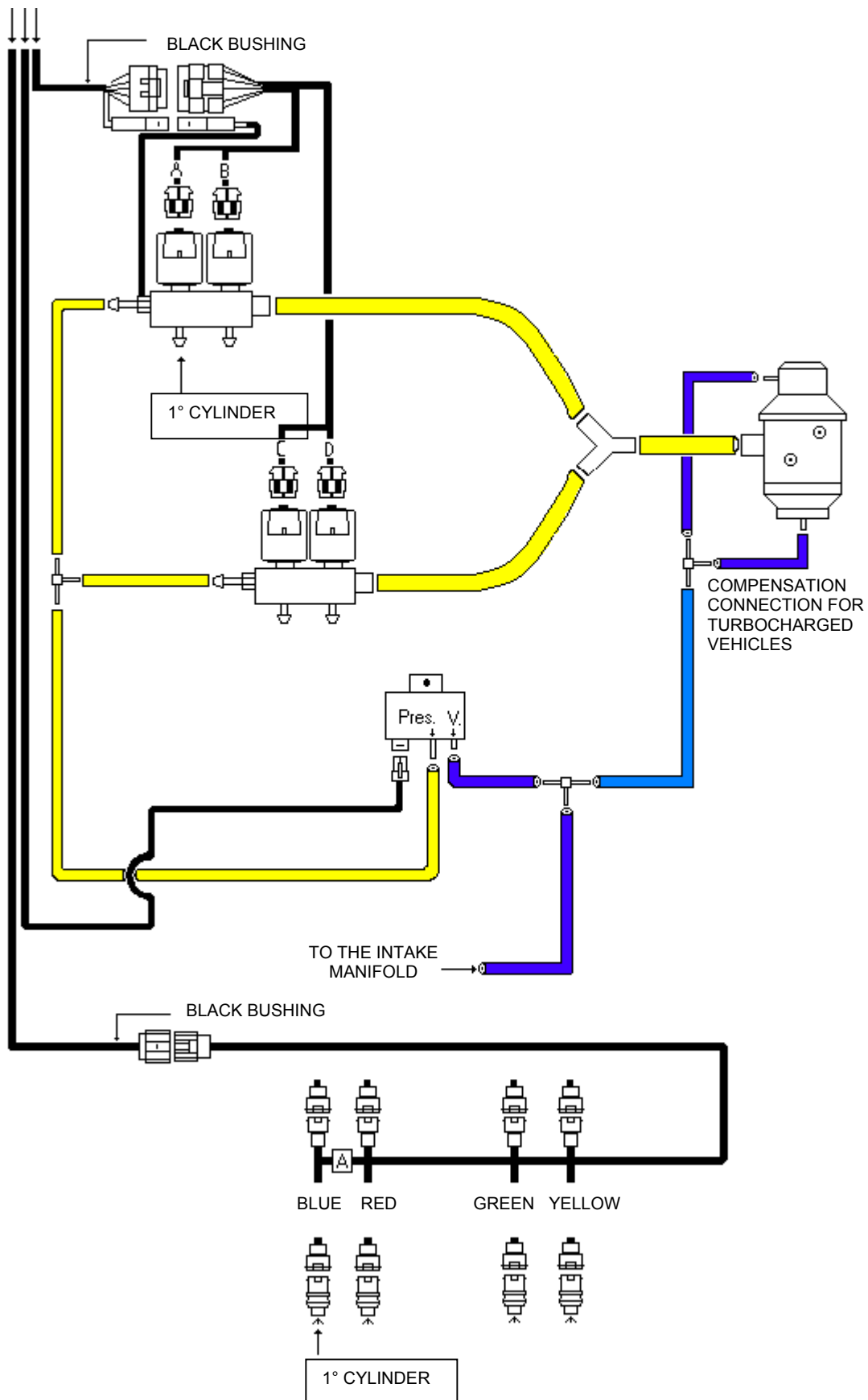

DIAGRAM FOR LPG 4 CYLINDER BOXER VEHICLES 2 REGULATORS

UP TO 140 KW

CONTINUING
FROM THE
PREVIOUS PAGE

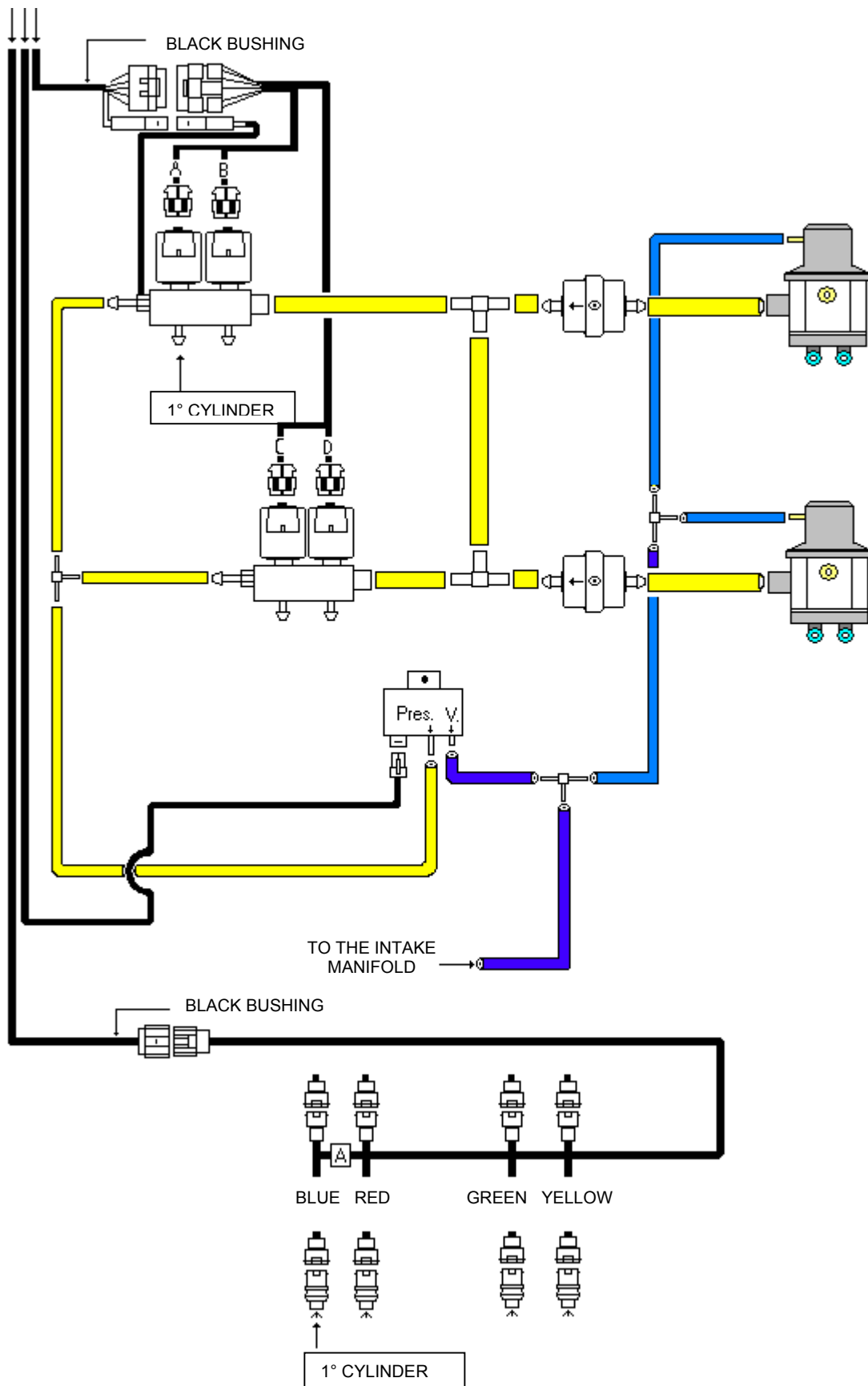

DIAGRAM FOR CNG 4 CYLINDER BOXER VEHICLES 2 REGULATORS UP TO 140 KW

CONTINUING
FROM THE
PREVIOUS PAGE

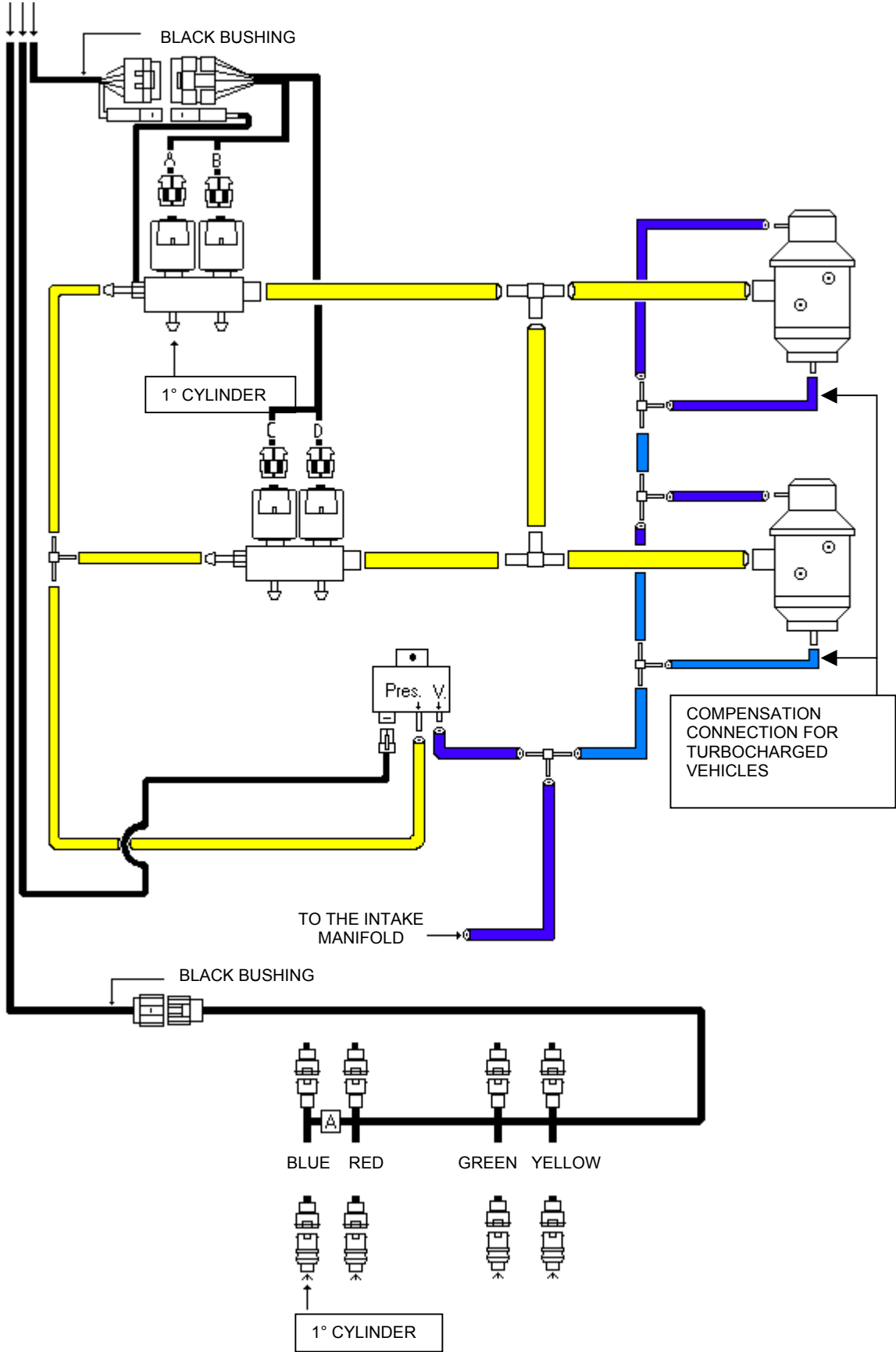

DIAGRAM FOR 5 - 6 - 8 CYLINDER VEHICLES

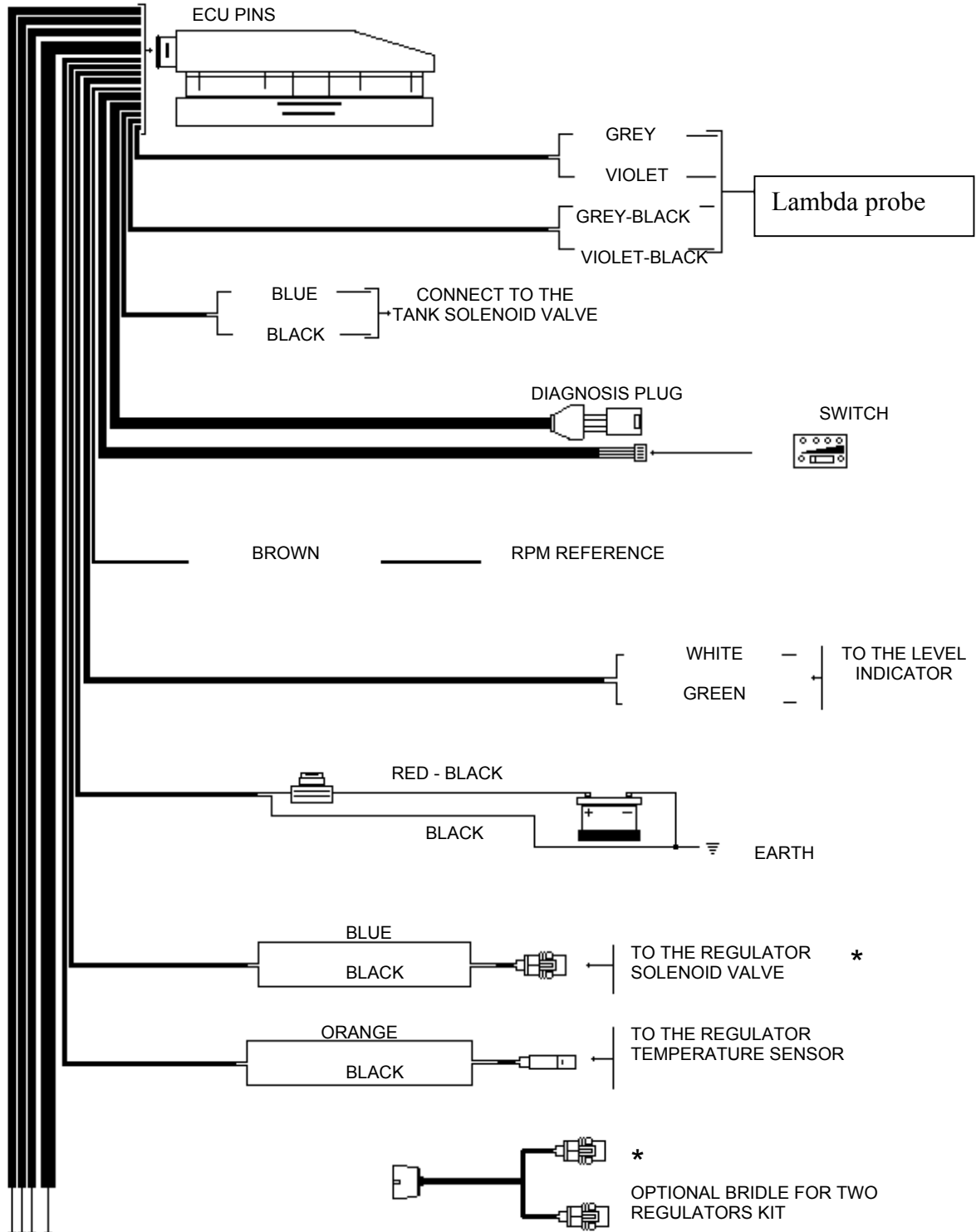

DIAGRAM FOR LPG 5 CYLINDER VEHICLES 1 REGULATOR UP TO 120 KW

CONTINUING FROM THE PREVIOUS PAGE

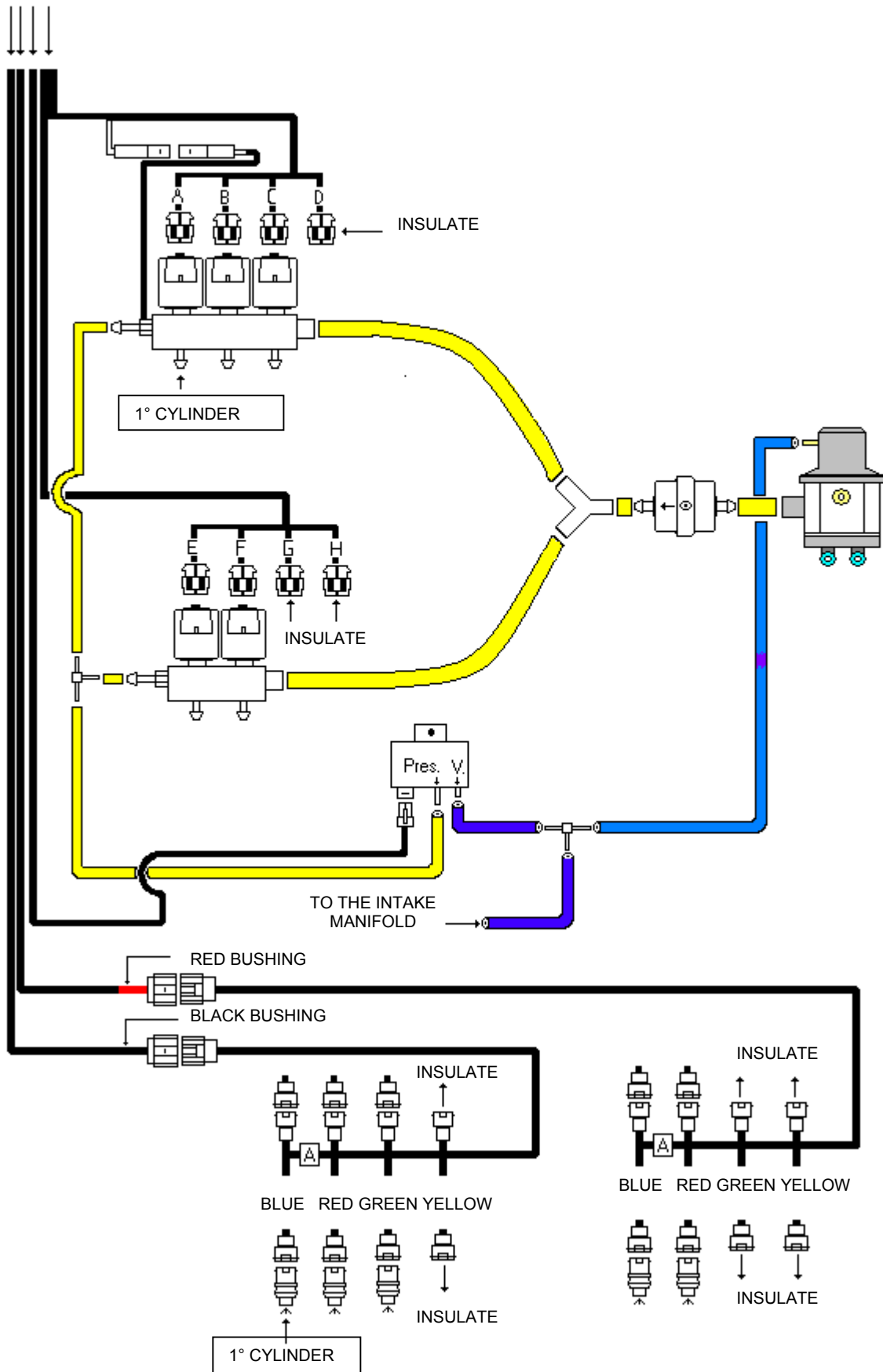

DIAGRAM FOR CNG 5 CYLINDER VEHICLES 1 REGULATOR UP TO 120 KW

CONTINUING
FROM THE
PREVIOUS PAGE

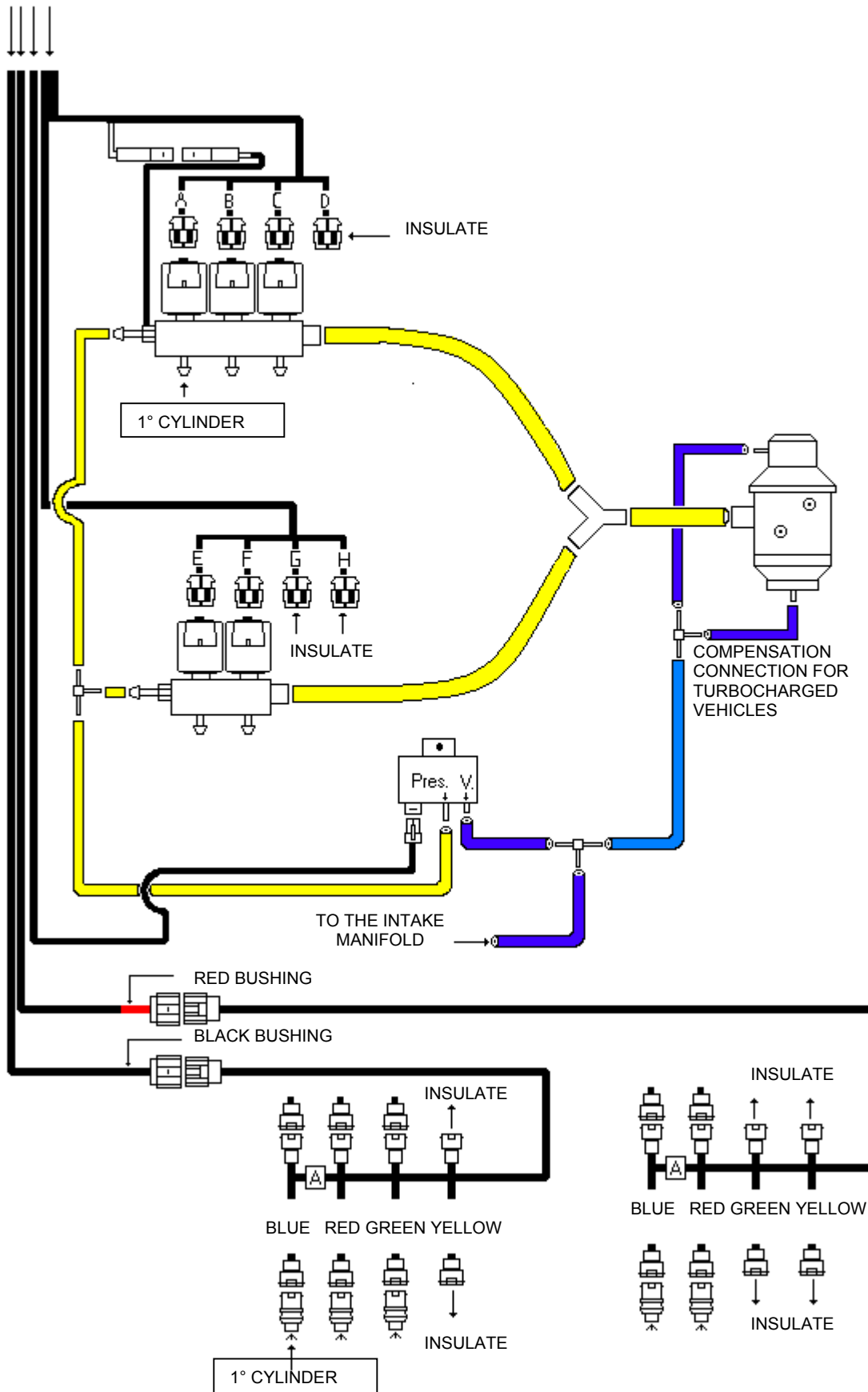

DIAGRAM FOR LPG 5 CYLINDER VEHICLES 2 REGULATORS UP TO 150 KW STD. RAIL – UP TO 190 KW SUP. RAIL

CONTINUING
FROM THE
PREVIOUS PAGE

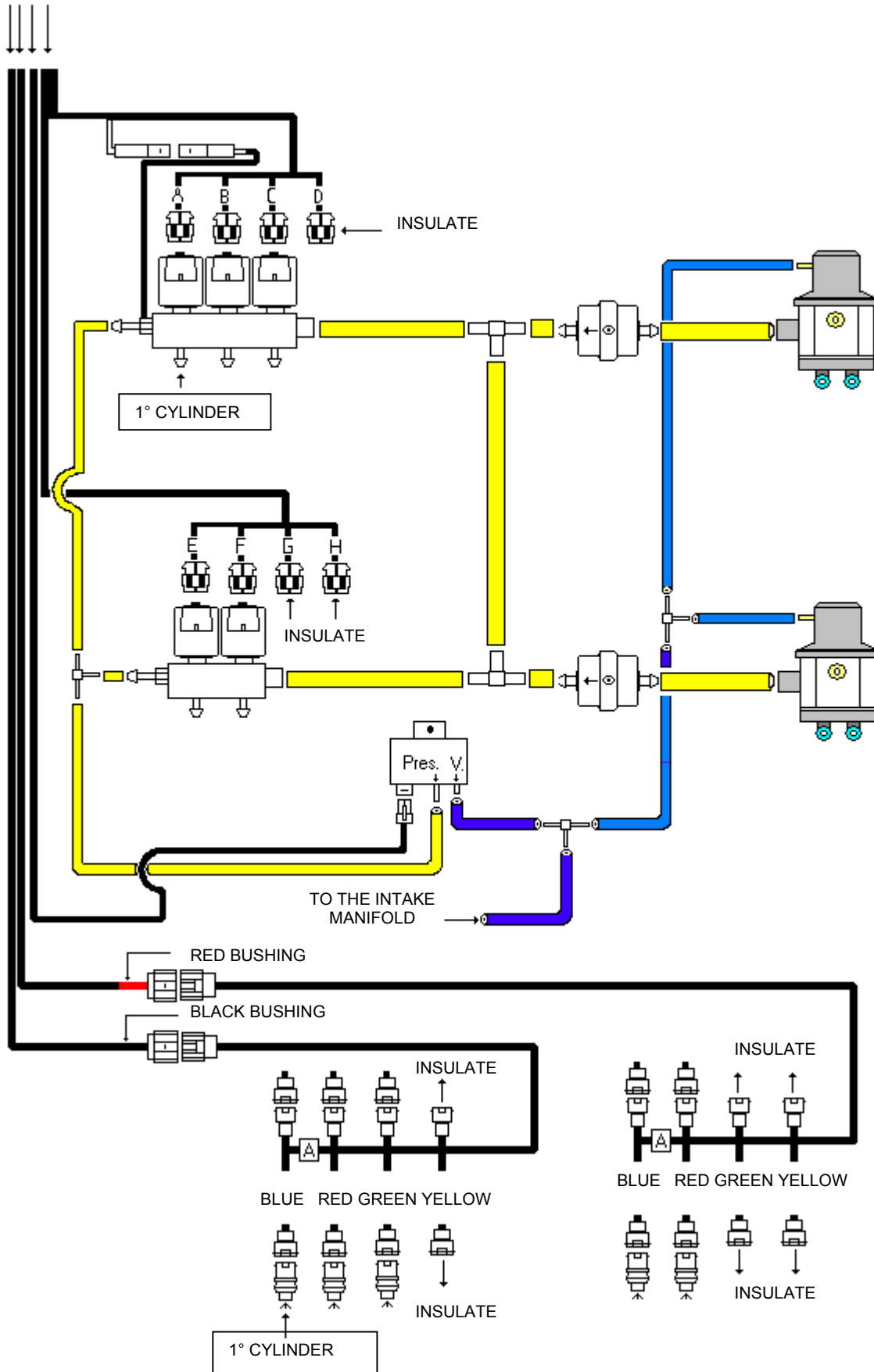

DIAGRAM FOR CNG 5 CYLINDER VEHICLES 2 REGULATORS UP TO 150 KW STD. RAIL – UP TO 190 KW SUP. RAIL

CONTINUING
FROM THE
PREVIOUS PAGE

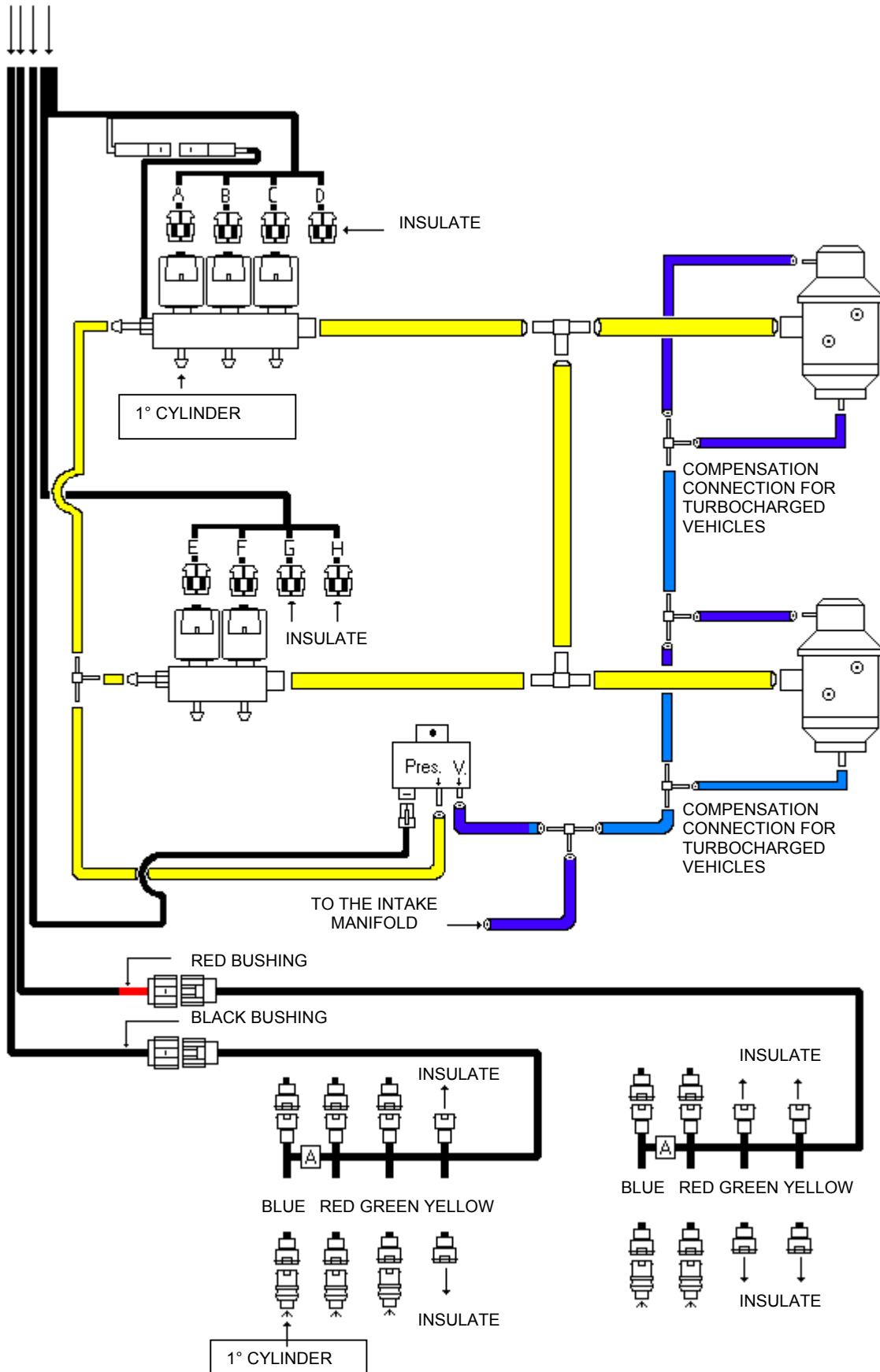

DIAGRAM FOR LPG 6 CYLINDER IN-LINE AND V-SHAPED VEHICLES 1 REGULATOR UP TO 120 KW

CONTINUING
FROM THE
PREVIOUS PAGE

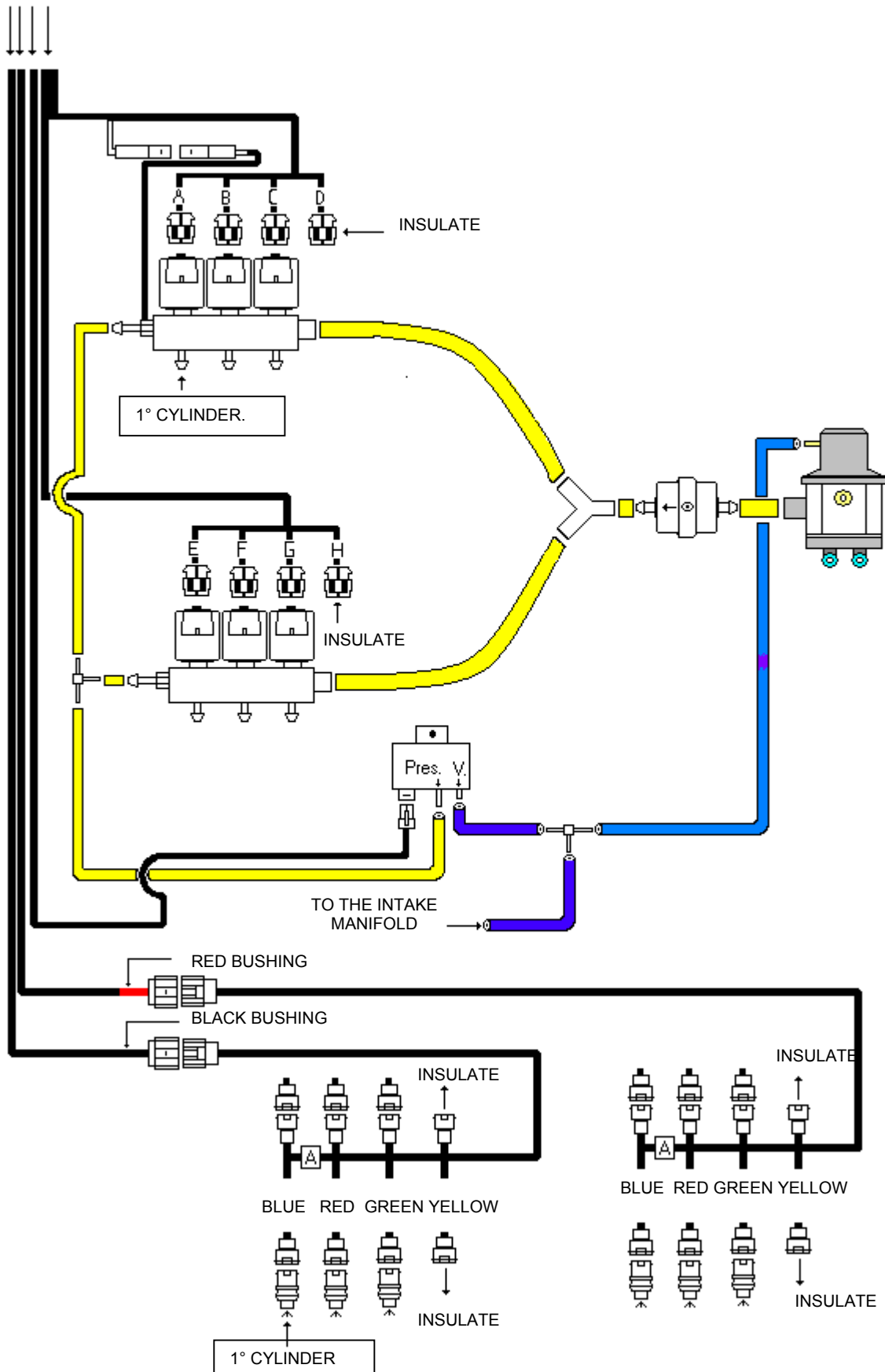

DIAGRAM FOR CNG IN-LINE AND V-SHAPED 6 CYLINDER VEHICLES – 1 REGULATOR UP TO 120 KW

CONTINUING
FROM THE
PREVIOUS PAGE

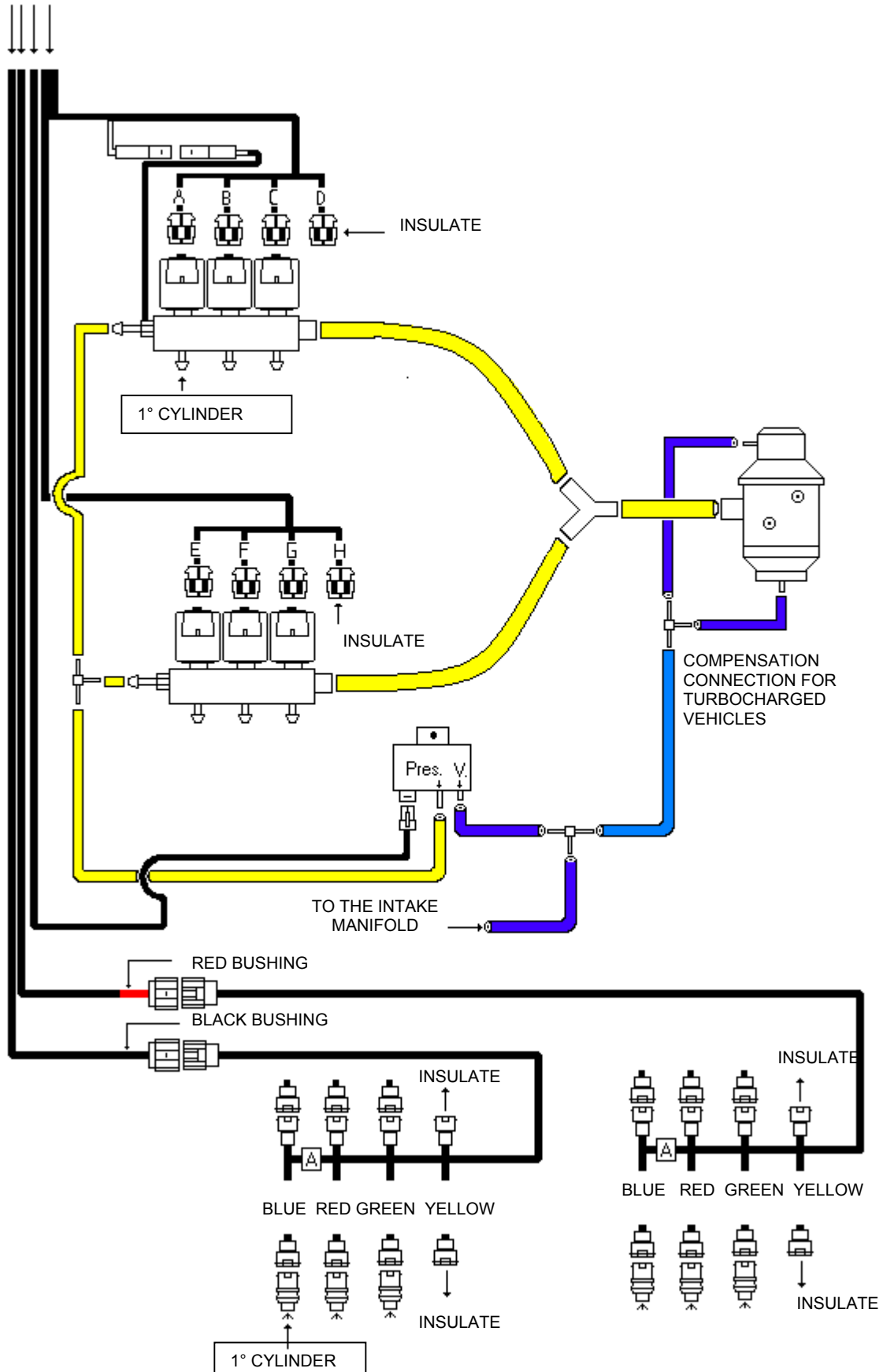

DIAGRAM FOR LPG IN-LINE AND V-SHAPED 6 CYLINDER VEHICLES 2 REGULATORS - UP TO 170 KW STD RAIL – UP TO 220 KW SUP. RAIL

CONTINUING
FROM THE
PREVIOUS PAGE

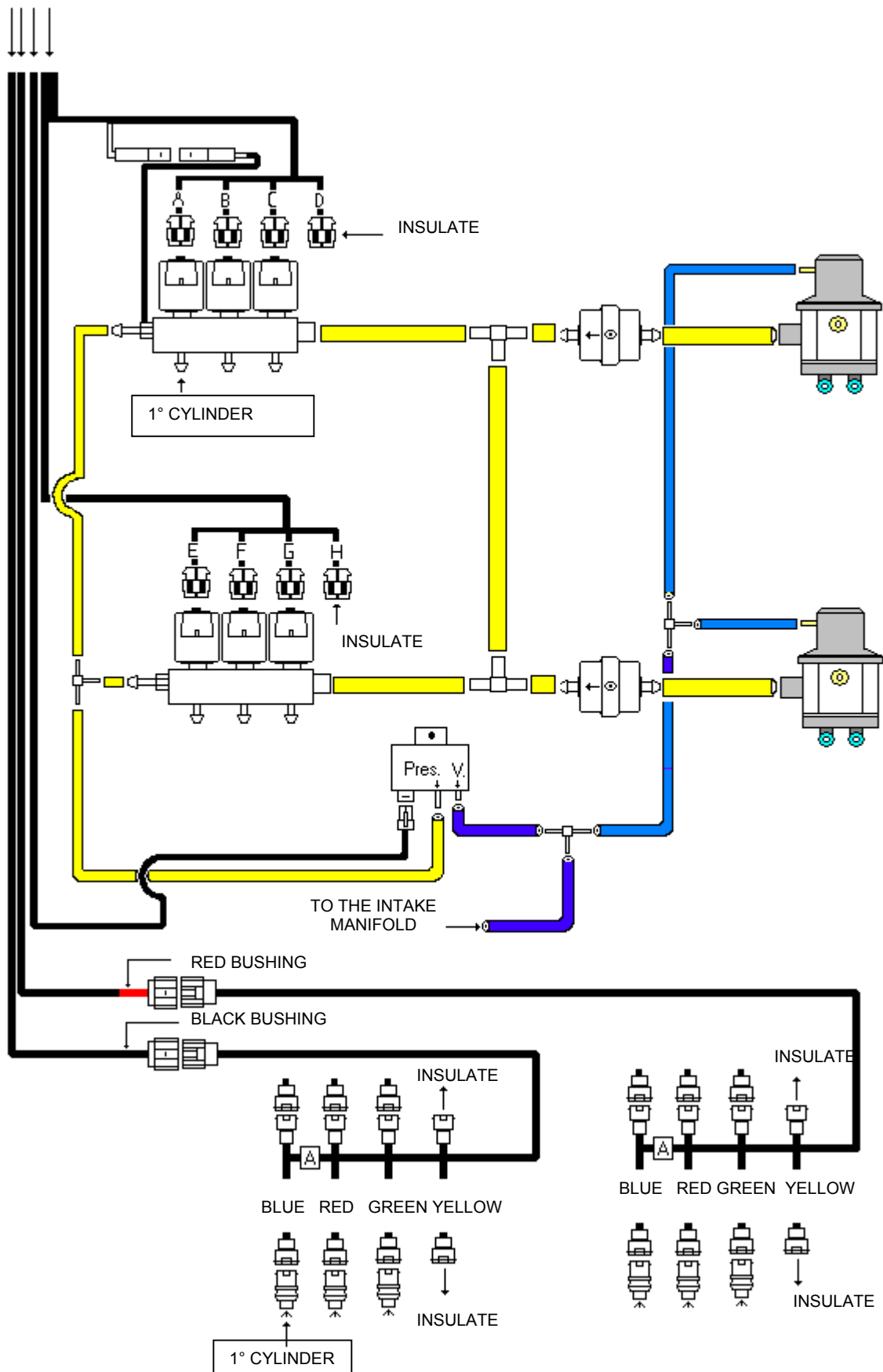

DIAGRAM FOR CNG IN-LINE AND V-SHAPED 6 CYLINDER VEHICLES – 2 REGULATORS – UP TO 170 KW STD. RAIL – UP TO 220 KW SUP. RAIL

CONTINUING
FROM THE
PREVIOUS PAGE

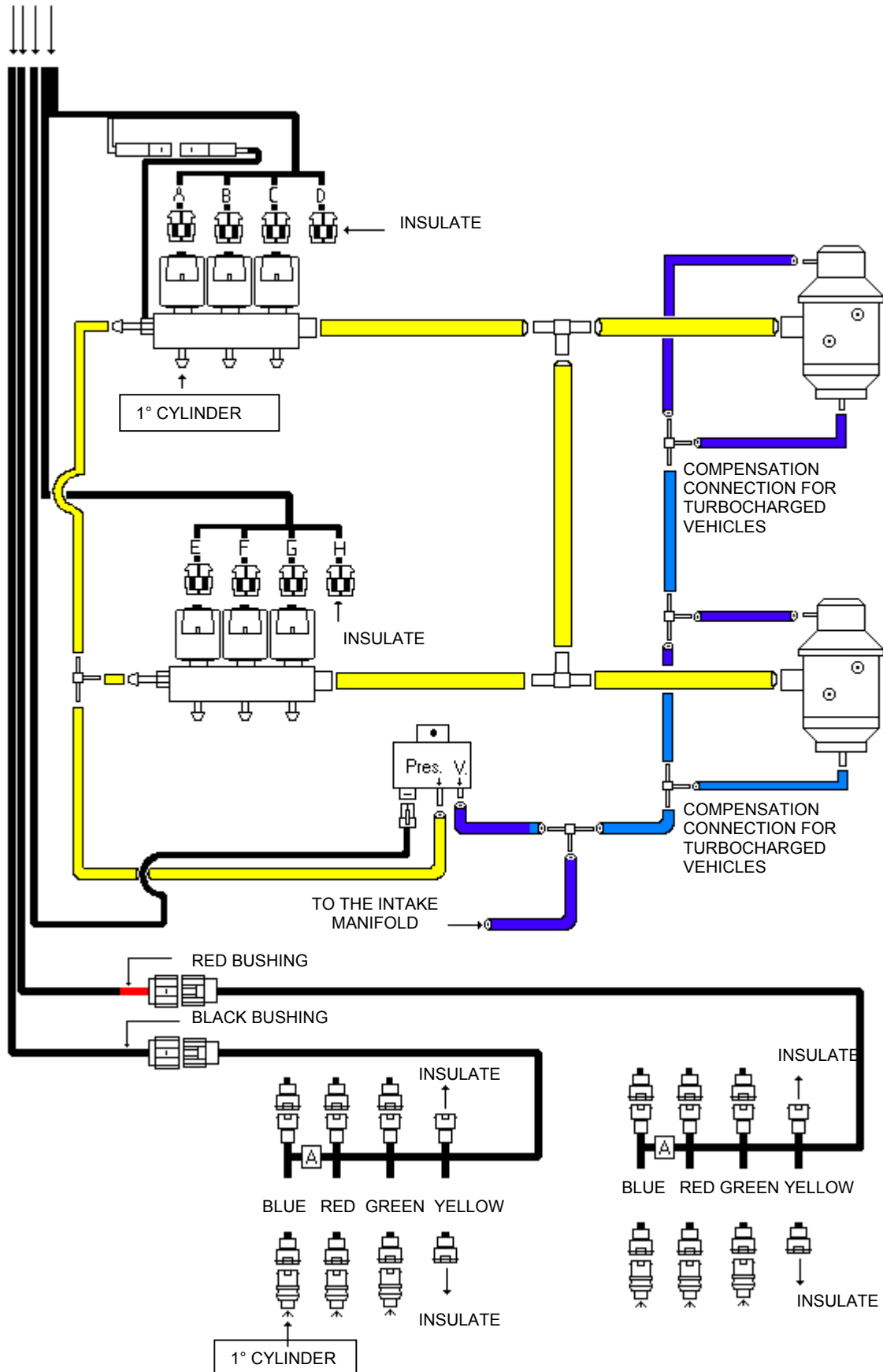

DIAGRAM FOR LPG V-SHAPED 8 CYLINDER VEHICLES – 2 REGULATORS - UP TO 200 KW STD. RAIL – UP TO 240 KW SUP. RAIL

CONTINUING
FROM THE
PREVIOUS PAGE

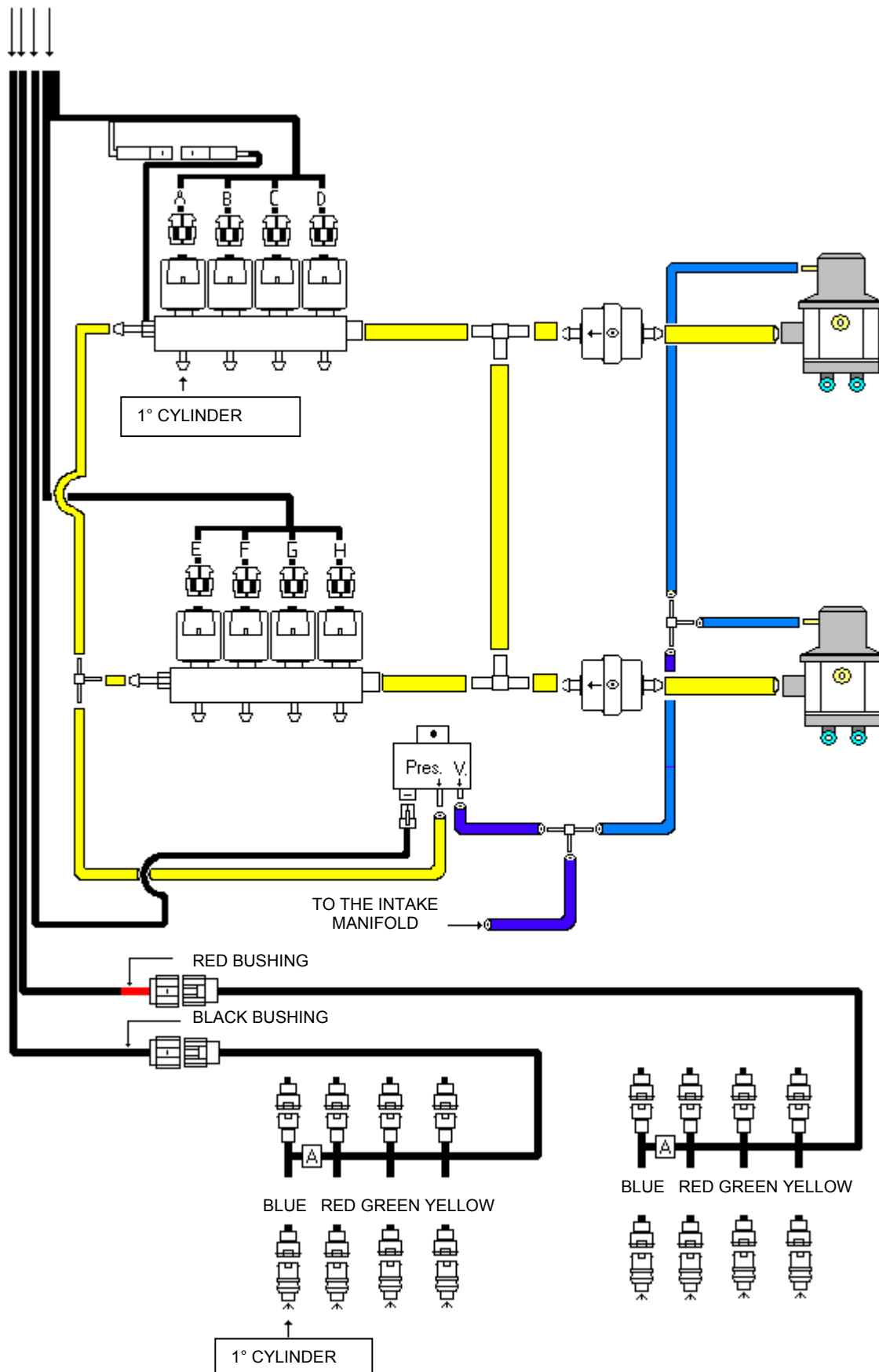

DIAGRAM FOR CNG V-SHAPED 8 CYLINDER VEHICLES - 2 REGULATORS UP TO 200 KW STD. RAIL – UP TO 240 KW SUP. RAIL

CONTINUING
FROM THE
PREVIOUS PAGE

