

Homologation:
E4 - 40/120 °C
CLASS 2
110R-000122
67R-010196

COMPONENTS	SPECIFICATIONS
Rail material	Plastic polymer
Solenoid coil	Voltage = 12 VDC Nominal power = 57.6 W Resistance = ±5% @20°D = 2.5
Pressure	1 bar LPG , 2 bar CNG
Flow	2.6 g/s @1 bar GPL 3.25 g/s @ 1.5 bar GPL 2.4 g/s @ 2 bar Metano

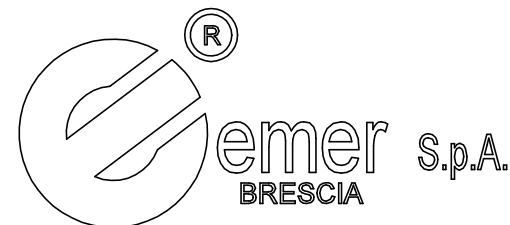
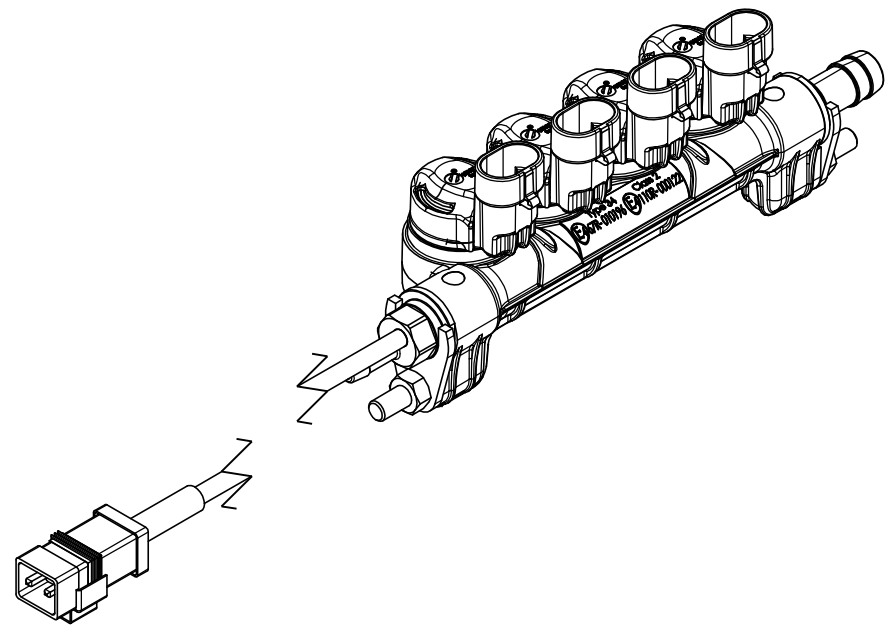

LPG/CNG 1-2 BAR INJECTOR RAIL WITH TEMPERATURE AND PRESSURE SENSOR
 HOMOLOGATION / APPROVAL ACCORDING TO: ECE R-110 NR. E4 110R-000122
 ECE 67-01 NR. E4 67R-010196
 Date:19-09-08
 Rev. 00

THIS IS A CONFIDENTIAL DRAWING
All proprietary rights reserved Emer S.p.A.
This drawing shall not be reproduced without written consent