

Components	Specifications
Rail material	Aluminium 2011
Solenoid coil	Voltage=12VDC Nominal power= 48 W Resistance ±5%@20°C=3 Ω
Pressure	1 Bar with LPG 2 Bar with CNG
Flow	Each single injector with nozzle D.4: - 3.36 g/s @1bar LPG - 3.10 g/s @ 2bar CNG

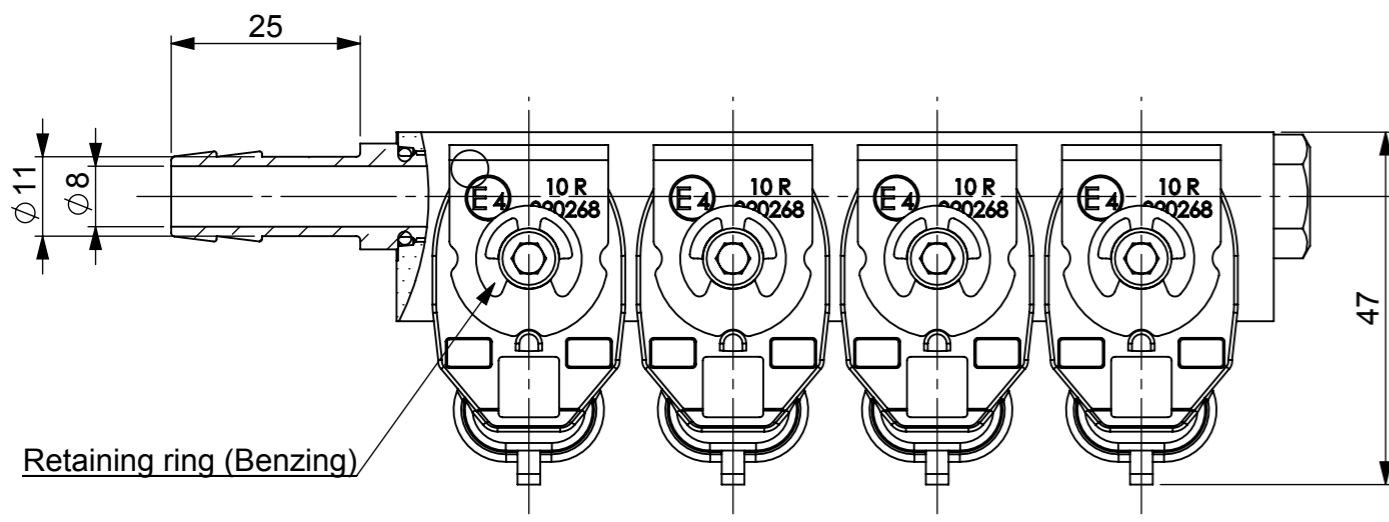

HOMOLOGATION:
E4 67R-010104
110R-000040
ISO15500 APPROVAL
LPG-CNG CLASS 2

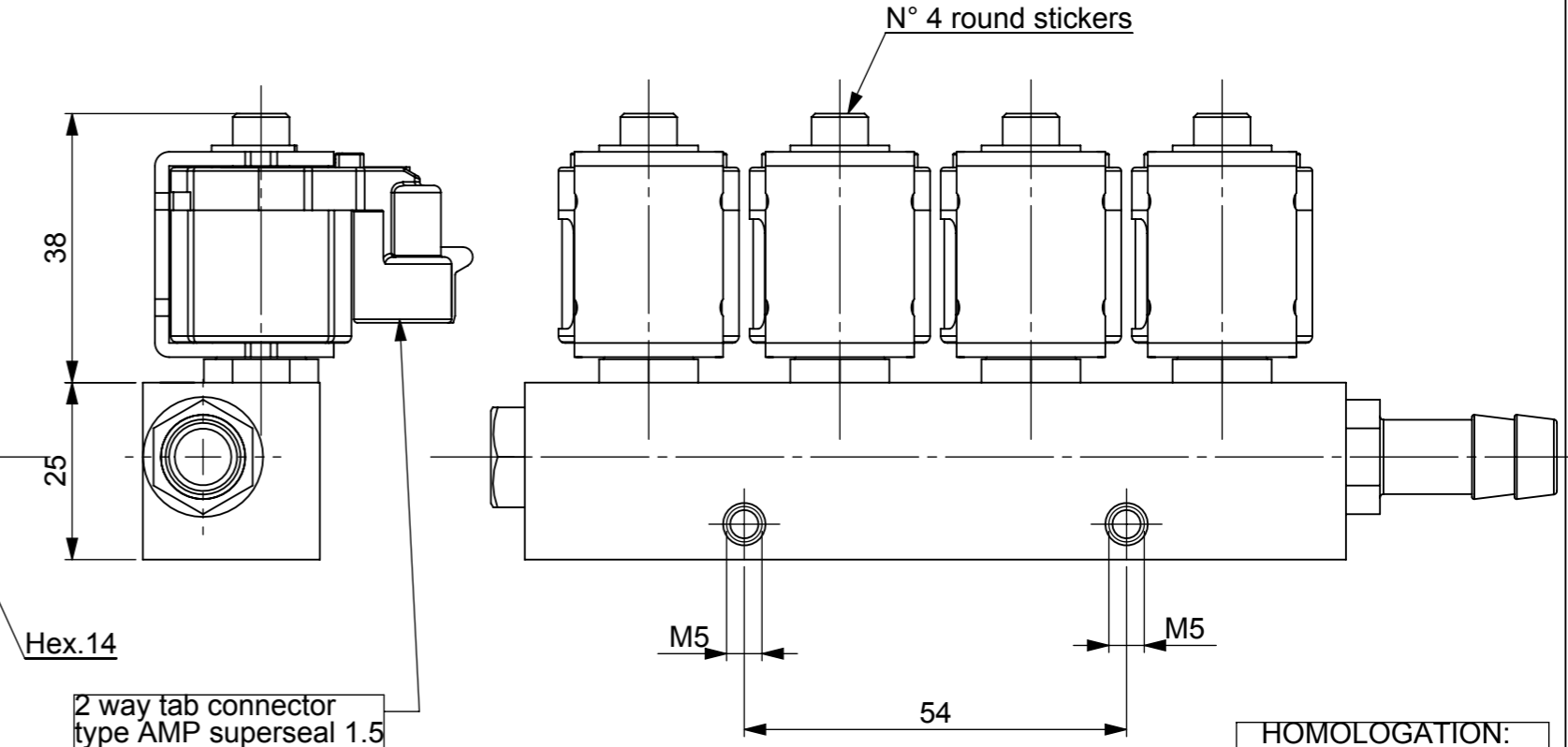
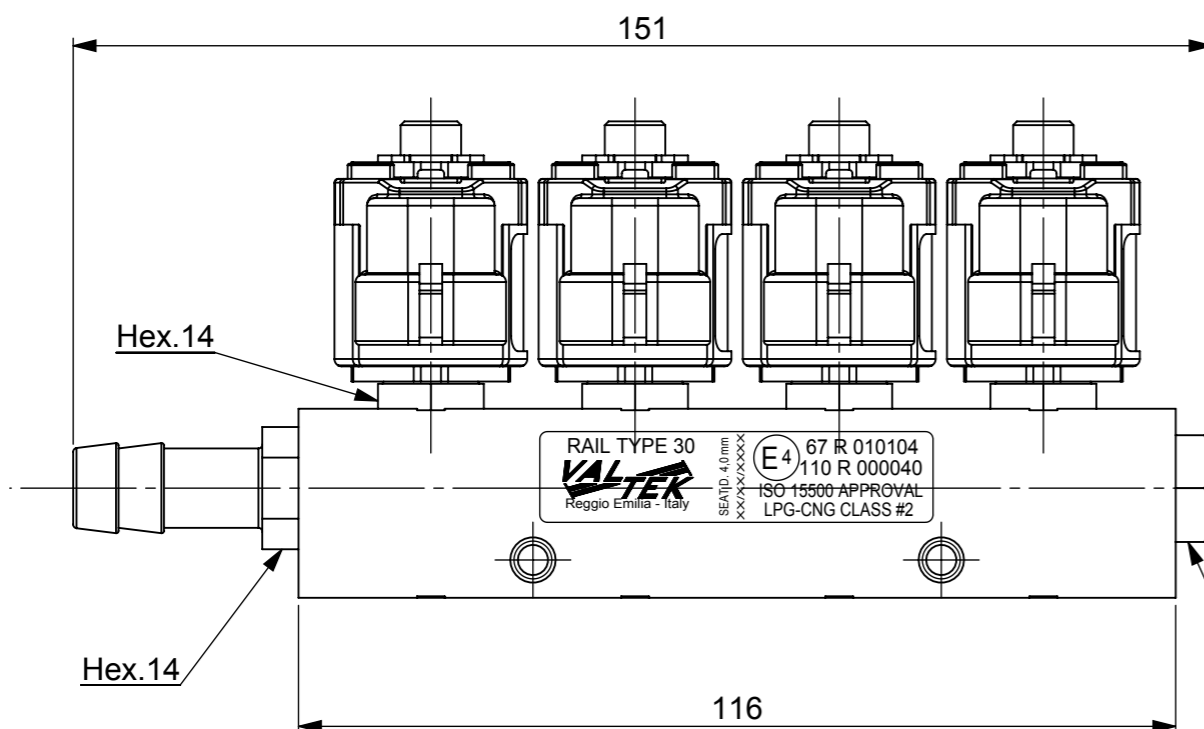
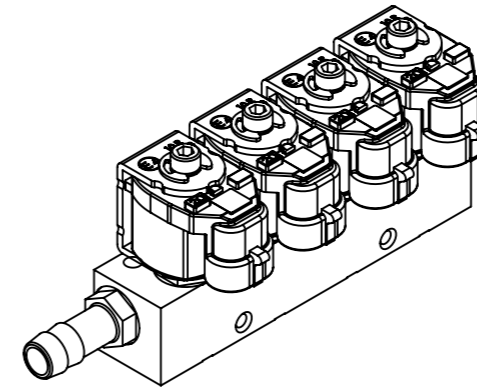
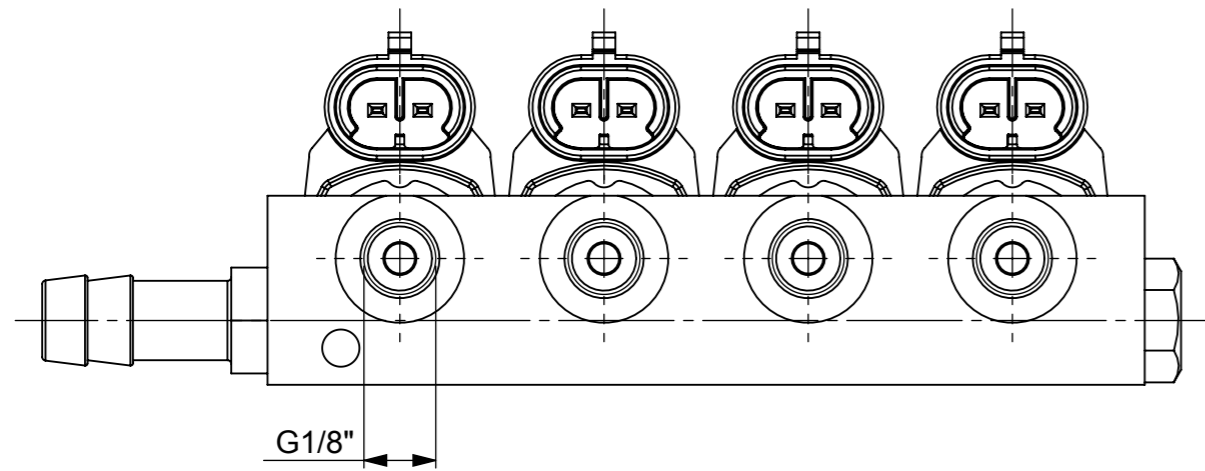

LPG/CNG 1-2 BAR INJECTOR RAIL
TYPE 30.EVG.117

Date:19-09-08
Rev. 00

THIS IS A CONFIDENTIAL DRAWING
All proprietary rights reserved Emer S.p.A.
This drawing shall not be reproduced without written consent